

serie

ULTRAV



электронасосы

многоступенчатые



ХАРАКТЕРИСТИКИ / CHARACTERISTICS CARACTERISTICAS / CARATERISTIQUES



ПРИМЕНЕНИЕ – многоступенчатый вертикальный центробежный насос из нержавеющей стали. Перекачивание чистой без примесей жидкости в частном, сельскохозяйственном и промышленном секторе; системы повышения давления; ирригация; питьевая и гликолевая вода; водоочистительные системы; пищевая промышленность; системы отопления и кондиционирования воздуха; моечные системы.

ПРЕИМУЩЕСТВА – моноблочная компактная конструкция; бесшумность; превосходные показатели продуктивности, позволяющие значительно снизить эксплуатационные расходы и затраты энергии; экономичность; превышающие стандартные габариты подшипники для долговечности в эксплуатации; промежуточная направляющая вала для обеспечения соосности вращения.

ОСОБЕННОСТИ КОНСТРУКЦИИ – пропускная способность: до 26 м³/h; суммарная высота напора: до 125 м; максимальное рабочее давление: 8 bar ≤ 6 рабочих колес; 14 bar > 6 рабочих колес; температурная зона жидкости: от +5 до +35 °C; температура окружающей среды: до 40 °C.

ДВИГАТЕЛЬ - двухполюсный асинхронный электродвигатель; однофазные модели – 230 В – 50 Гц с тепловой защитой до P2= 1,85 Kw; трехфазные модели – 230/400 В – 50 Гц; изоляция класса F; степень защиты IP 44.

МАТЕРИАЛЫ – корпус с фланцевым входным и выходным отверстием – чугун; обшивка, кольцо герметизирующего уплотнения – хромоникелевая сталь AISI 304; рабочие колеса, диффузоры - Noryl® с добавлением стекловолокна (GFN2V); вал привода насоса - хромоникелевая сталь AISI 303; опора двигателя - алюминиевый сплав; герметизирующее уплотнение – графитокерамика до 6 ступеней, графит-кремний – начиная с 7 ступеней; промежуточная направляющая вала – керамика-вольфрам.

USES - Multistage vertical pumps. Pumping of clean non-loaded fluids in the domestic, agricultural and industrial sectors; pressurizing systems; irrigation; drinking and glycol water; water treatment; food industry; heating and air conditioning; washing system.

ADVANTAGES - Closed coupled and compact; silent; excellent efficiency that allows a reduction of running cost ad powers; economical; over-dimensioned bearings for longer life of the machines; intermediate shaft guiding stage for concentricity of rotation.

CONSTRUCTION FEATURES - Capacity: up to 26 m³/h; total Head: up to 125 m.; maximum working pressure: 8 bar ≤ 6 impellers, 14 bar > 6 impellers; maximum liquid temperature: from +5 to +35 °C; ambient temperature: max 40 °C.

MOTOR - 2 pole induction Motor; single phase 230V - 50Hz with thermal protector up to P2= 1,85 kW; three phase 230-400V - 50 Hz; insulation class F; protection degree IP 44.

MATERIALS - Flanged siction pump body: cast iron; flanged delivery pump body: cast iron; shell: chromo-nickel steel AISI 304; impellers, diffusers: Noryl® reinforced with fiber glass (GFN2V); pump shaft: AISI 303 chromo-nickel steel; motor bracket: cast iron; mechanical seal: ceramic-graphite up to 6 stages - graphite-silicon carbide from 7 stages; intermediate shaft guiding stage bush: ceramic-tungsten carbide.

UTILIZACIONES - Bombas centrifugas verticales. Bombeo de líquidos químicamente y mecánicamente no agresivos en el sector doméstico, agrícola e industria; sistemas de presurización; riegos; agua potable o con glycol; tratamientos del agua; industria alimenticia; calefacción y refrigeración; sistemas de lavado.

VENTAJAS - Versión monobloc compacta con medidas reducidas; extrema silenciosidad de funcionamiento; excelente rendimiento con desminución de los costes de ejercicio y de las potencias; economica; cojinetes del motor sobredimensionados para una mayor duración; cojinete intermedio guía-eje que garantiza la coaxialidad de rotación.

CARACTERÍSTICAS CONSTRUCTIVAS -Caudal hasta los 26 m³/h; prevalencia hasta los 125 mt.; maxima presión de ejercicio 8 bar ≤ 6 rodetes, 14 bar > 6 rodetes; temperatura de ejercicio del liquido bombeado: de +5 a +35 °C; temperatuta del ambiente max 40°C.

MOTOR - Motor de 2 polos a inducción; monofasico 230v-50hz dotado de protección térmica hasta P2= 1,85 kW; trifasico 230/400v-50hz; aislamiento clase F; protección IP44.

MATERIALES - Bidas de aspiración/envío cuerpo bomba: fundición; camisa: acero cromo-níquel AISI304; rodetes, difusores: Noryl® reforzado con fibra de vidrio (GFN2V); eje: acero cromo-níquel AISI303; soporte motor: fundición; sello mecánico: cerámica-grafito hasta los 6 estadios - grafito-carburo de silicio de los 7 estadios; cojinete intermedio guía-eje: ceramica-carburo de tungsteno.

UTILISATION - Pompes multicellulaires verticales. Pour le pompage d'eaux propres non chargées pour des applications domestiques, agricoles, industrielles; groupes de surpression; irrigation; eau potable ou solution de glycol; traitement des eaux; industrie alimentaire; chauffage et Climatisation; stations de lavage auto.

AVANTAGES - Version monobloc compact; silencieux; rendement excellent avec une diminution remarquable des coût de fionnement et des puissance; économique; roulements surdimensionnés et étage de guidage intermédiaire pour une durée de vie prolongée des machines; roulement intermédiaire étage de guidage qui garantie le coaxialité de rotation.

CARACTÉRISTIQUES D'EXÉCUTION - Débit jusqu'à 26 m³/h; hauteur jusque'à 125 m.; pression max. de fonctionnement 8 bar ≤ 6 roues, 14 bar 6 roues; température du liquide pompé: de +5 à +35 °C; température ambiante max 40 °C.

MOTEUR - Moteur 2 pôles à induction; monophasé 230 V – 50 Hz avec protection thermique jusqu'à P2= 1,85 kW; triphasé 230/400 V – 50 Hz; isolation en classe F; degré de protection IP 44.

MATERIAUX - Brides corps de pompe: fonte; chemise externe: acier au chrome-nickel AISI 304; roues, diffuseurs: Noryl® renforcé avec fibre de verre (GFN2V); arbre: acier au chrome-nickel AISI 303; support moteur: fonte; garniture mécanique: céramique – graphite jusqu'à 6 étages, graphite - carbure de silicium à partir de plus de 7 étages; douilles étage de guidage intermédiaire: céramique - carbure de tungstène.



MULTICELLULAIRES

ELECTROPOMPES

MULTICELULARES

ELECTROBOMBAS

ELECTRIC PUMPS

MULTISTAGE

serie

ULTRA/V

электронасосы

МНОГОСТУПЕНЧАТЫЕ

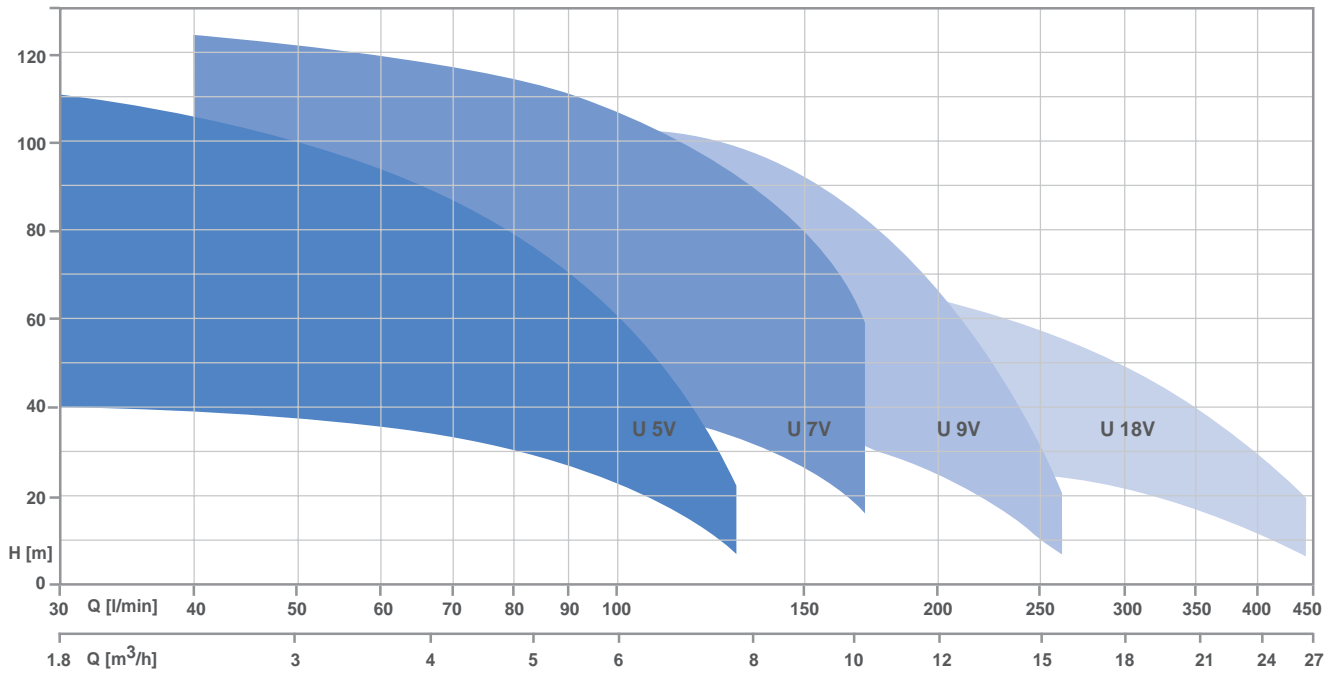

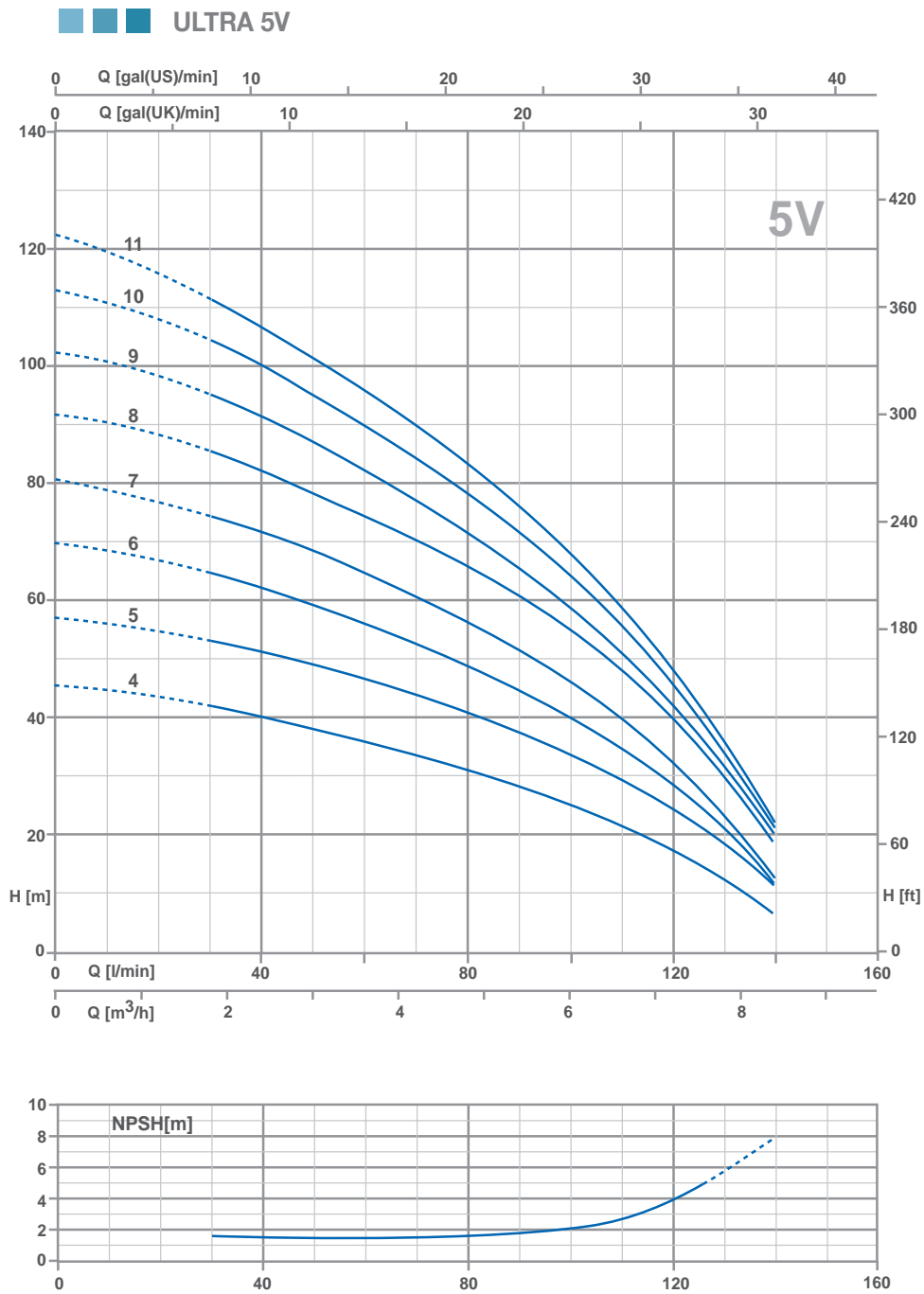

ТЕХНИЧЕСКИЕ ДАННЫЕ / Technical data / Datos técnicos / Données techniques

МОДЕЛЬ / TYPE / MODELO / MODÈLE				P2				P1 (kW)				AMPERE		Q (m³/h - l/min)									
1~	3~	P2		P1 (kW)		1~	3~	0	1.8	2.4	3.6	4.8	6	7.2	8.4	H (m)							
		(HP)	(kW)	1~	3~	1x230V 50Hz	3x400V 50Hz	0	30	40	60	80	100	120	140								
230 V - 50 Hz	230 / 400 V - 50 Hz																						
U 5V-120/4	U 5V-120/4 T	1.2	0.9	1.13	1.13	5.2	2.5	45.3	41.3	39.6	35.6	30.8	24.9	17.6	6.4								
U 5V-150/5	U 5V-150/5 T	1.5	1.1	1.47	1.39	6.8	2.8	56.8	53	51	46.1	40.1	33.3	24.8	11.5								
U 5V-180/6	U 5V-180/6 T	1.8	1.3	1.7	1.62	7.7	3	69.3	64.4	62	55.6	48.2	39.6	28.8	12								
U 5V-200/7	U 5V-200/7 T	2	1.5	2	1.86	9	3.4	80.3	73.6	71	64.5	56.1	46	33.4	12.5								
U 5V-250/8	U 5V-250/8 T	2.5	1.85	2.37	2.17	10.7	4.1	91.4	85	81.8	74.3	65.5	54.7	40.4	19.1								
U 5V-280/9	U 5V-280/9 T	2.8	2.1	2.6	2.4	11.7	4.4	102.1	94.6	90.7	81.6	71	58.5	42.3	20.1								
U 5V-300/10	U 5V-300/10 T	3	2.2	2.84	2.73	12.8	4.9	112.7	103.9	99.9	89.8	78.25	64	46.4	21								
U 5V-350/11	U 5V-350/11 T	3.5	2.57	2.95	2.89	13.3	5	122	111.2	106.3	95.6	83.1	67.6	48.2	22								

ULTRA V

serie

электронасосы
МНОГОСТУПЕНЧАТЫЕ

ULTRA 7V

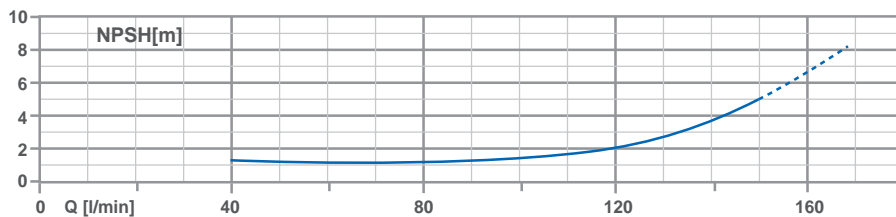
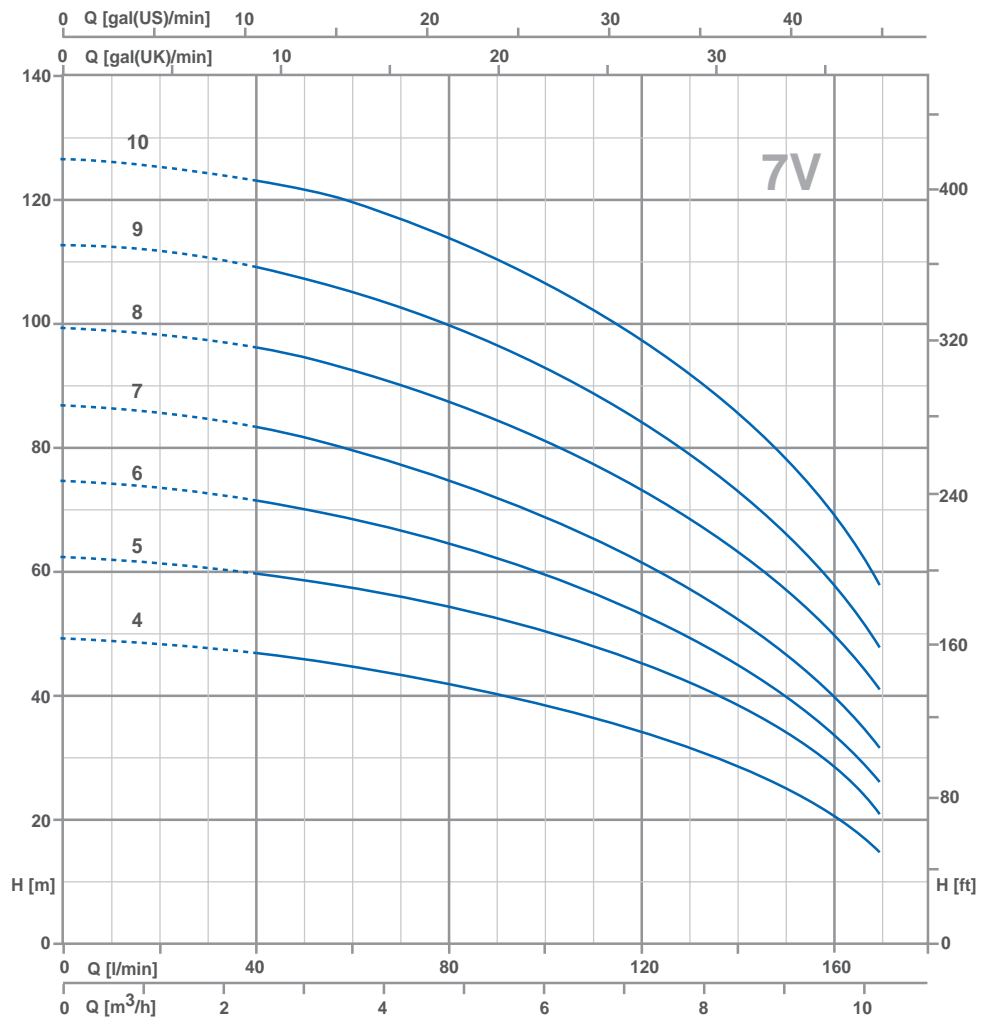

ТЕХНИЧЕСКИЕ ДАННЫЕ / Technical data / Datos técnicos / Données techniques

МОДЕЛЬ / TYPE / MODELO / MODÈLE		P2		P1 (kW)		AMPERE		Q (m ³ /h - l/min)											
1~	3~	(HP)	(kW)	1~	3~	1~	3~	0	2.4	3.6	4.8	6	7.2	8.4	9.6	10.2			
230 V - 50 Hz	230 / 400 V - 50 Hz							0	40	60	80	100	120	140	160	170			
						1x230V 50Hz		3x400V 50Hz		H (m)									
U 7V-180/4	U 7V-180/4 T	1.8	1.3	1.83	1.71	8.3	3.2	49.5	47.4	45.3	42.5	39.2	34.8	29.4	22.6	16.9			
U 7V-250/5	U 7V-250/5 T	2.5	1.85	2.39	2.15	10.9	4.2	62.6	60.6	58.2	55.1	51.1	45.8	39	29.8	21.5			
U 7V-300/6	U 7V-300/6 T	3	2.2	2.68	2.63	12.2	5	74.8	71.5	68.3	64.5	59.3	53	44.6	34.5	26.7			
-	U 7V-350/7 T	3.5	2.57	-	3.04	-	5.5	87.2	83.3	79.3	74.6	68.9	61.9	52.5	41	32.2			
-	U 7V-400/8 T	4	3	-	3.6	-	6.8	99.5	96.1	92.6	87.9	81.9	74.6	64.4	51	43			
-	U 7V-450/9 T	4.5	3.31	-	4.09	-	7	113.2	109.7	105.4	100.1	93.5	84.8	73.6	59.6	49			
-	U 7V-550/10 T	5.5	4	-	4.6	-	8.3	127	123.8	119.6	114.1	106.6	97.6	86	70.3	61			

ULTRA 9V

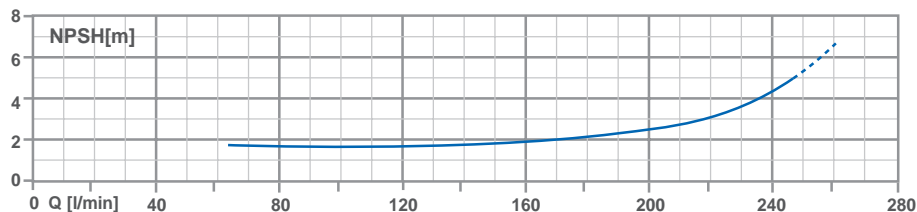
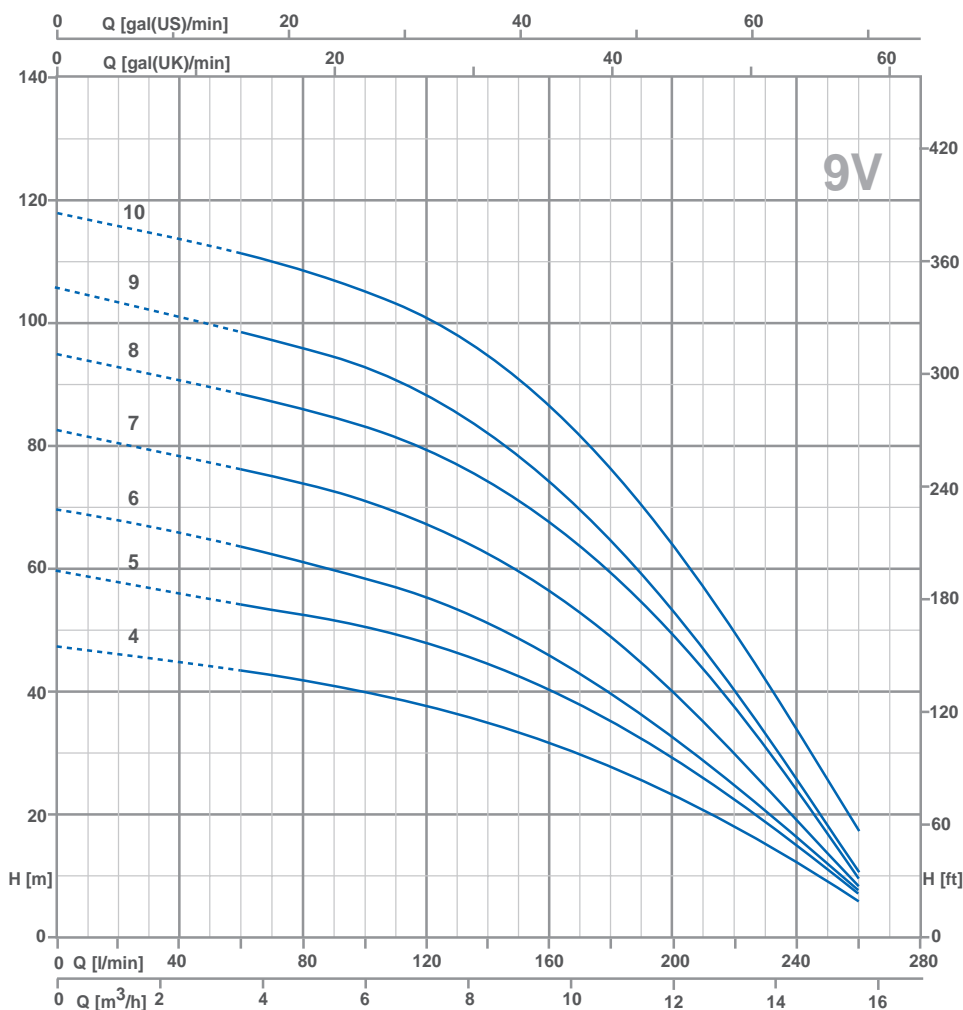

ТЕХНИЧЕСКИЕ ДАННЫЕ / Technical data / Datos técnicos / Données techniques

МОДЕЛЬ / TYPE / MODELO / MODÈLE				P2		P1 (kW)		AMPERE		Q (m³/h - l/min)														
1~	3~	(HP)	(kW)	1~	3~	1~	3~	1~	3~	H (m)														
										0	3.6	4.8	6	7.2	8.4	9.6	10.8	12	13.2	14.4	15.6			
										0	60	80	100	120	140	160	180	200	220	240	260			
230 V - 50 Hz	230 / 400 V - 50 Hz							1x230V 50Hz	3x400V 50Hz															
U 9V-200/4	U 9V-200/4 T	2	1.5	1.88	1.77	8.4	3.3	47.1	43.5	42	40.5	38.3	35.7	32.4	28.4	23.8	18.9	13.3	7.3					
U 9V-250/5	U 9V-250/5 T	2.5	1.85	2.32	2.18	10.6	4.3	59.2	54.4	52.4	50.4	47.9	44.8	40.5	35.5	29.8	23.5	16.3	8.5					
U 9V-300/6	U 9V-300/6 T	3	2.2	2.74	2.64	12.2	4.8	69.4	63.7	61.4	58.8	55.6	51.6	46.5	40.3	33.5	25.4	17	9					
-	U 9V-400/7 T	4	3	-	3.09	-	5.7	82	76	73.7	70.9	67.5	63	57	49.7	41	31.2	20.1	9.5					
-	U 9V-450/8 T	4.5	3.31	-	3.67	-	6.4	94.5	88.4	86	83	79.4	74.7	68	59.8	49.8	38.9	27	11.6					
-	U 9V-500/9 T	5	3.7	-	4.03	-	6.9	105.4	98.9	96.1	92.7	88.5	82.8	75	65.4	54.5	41.8	28	12.5					
-	U 9V-550/10 T	5.5	4	-	4.57	-	8.3	117.6	111	108.4	105.3	101.1	95.1	87.2	76.7	64.8	51.2	36.4	20.1					

ULTRAV

serie

электронасосы
МНОГОСТУПЕНЧАТЫЕ

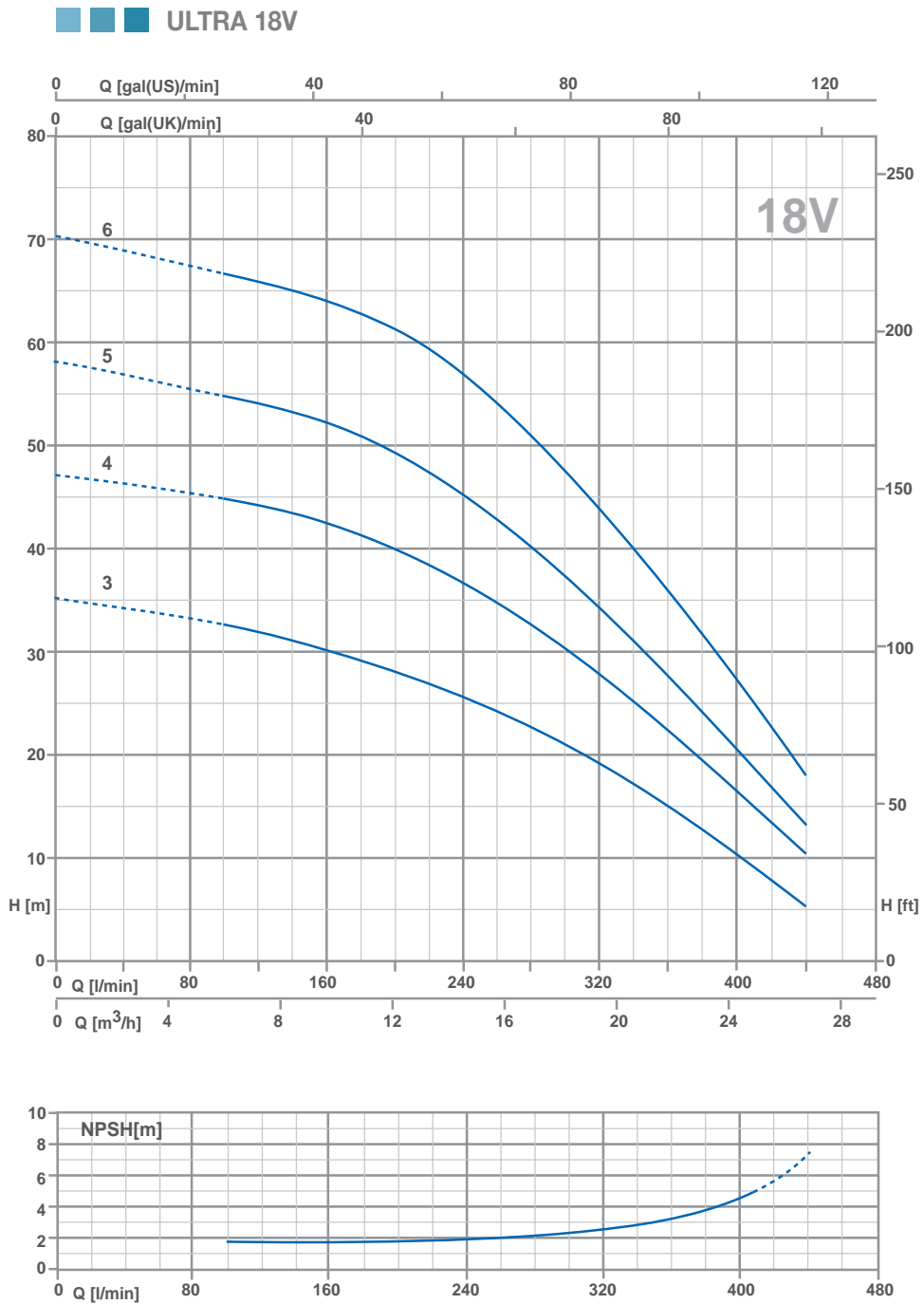

ТЕХНИЧЕСКИЕ ДАННЫЕ / Technical data / Datos técnicos / Données techniques

TIPO/TYPE MODELO/MODÈLE	P2		P1 (kW)	AMPERE	Q (m³/h - l/min)																			
				3~	0	6	7.2	8.4	9.6	10.8	12	13.2	14.4	15.6	16.8	18	19.2	20.4	21.6	22.8	24	25.2	26.4	
					0	100	120	140	160	180	200	220	240	260	280	300	320	340	360	380	400	420	440	
230 / 400 V - 50 Hz	(HP)	(kW)	3~	3x400V 50Hz	H (m)																			
U 18V-250/3 T	2.5	1.85	2.19	4.3	35	32.7	32.2	31.4	30.5	29.5	28.3	26.7	25.5	24.3	22.8	21.2	19.3	17.3	15.1	12.9	10.8	8.7	6.1	
U 18V-400/4 T	4	3	2.99	5.5	47.2	44.6	44.1	43.3	42.4	41.2	40	38.5	36.7	34.9	32.9	30.5	27.9	25.3	22.7	20	17.1	14.3	11.3	
U 18V-450/5 T	4.5	3.31	3.68	6.6	57.8	54.8	54.2	53.3	52.1	50.8	49.2	47.6	45.4	43.2	40.6	37.7	34.7	31.5	28.2	24.8	21.4	17.8	14.1	
U 18V-550/6 T	5.5	4	4.51	8.7	70	66.6	66.1	65.4	64.3	63	61.2	59.1	56.8	54.2	51.3	47.6	44	40.2	36.5	32.4	28.4	24	19.3	

■ ■ ■ ULTRA 5V - ULTRA 7V - ULTRA 9V - ULTRA 18V

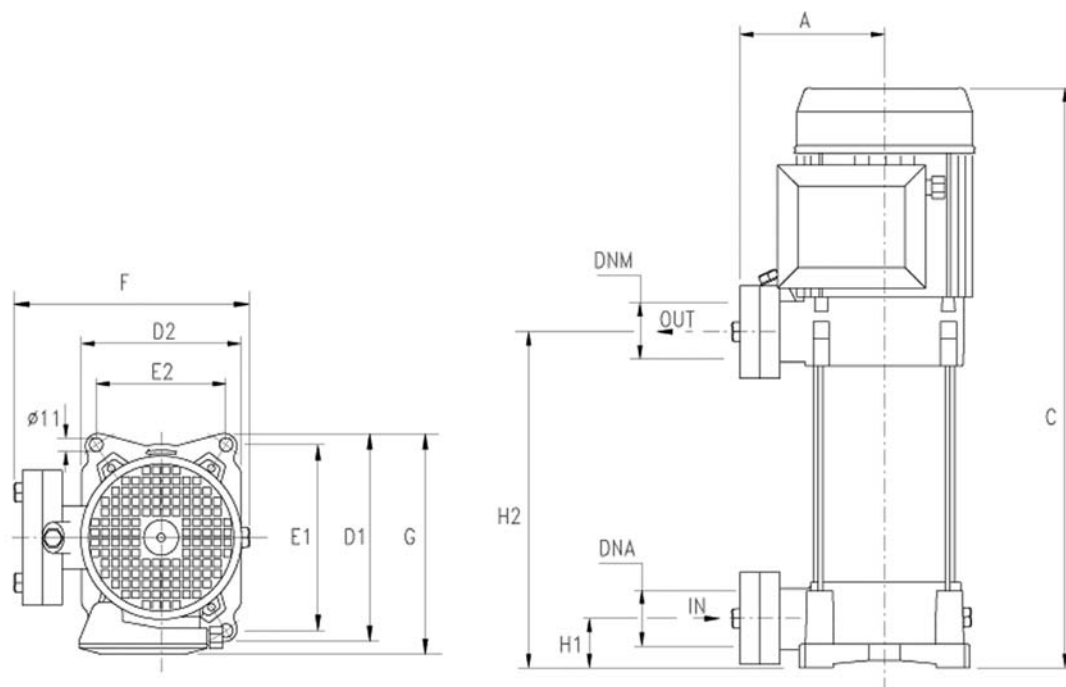

МОДЕЛЬ / TYPE MODELO / MODÈLE	РАЗМЕРЫ / DIMENSIONS / DIMENSIONES / DIMENSIONS (mm)										DNA	DNM		
	A	C	D1	D2	E1	E2	F	G	H1	H2				
U 5V-120/4	135	389	204	162	178.5	125	229	213	40	178	1"1/4 G	1"1/4 G		
U 5V-150/5	135	443	204	162	178.5	125	229	215	40	208.5				
U 5V-180/6	135	467	204	162	178.5	125	229	215	40	232.5				
U 5V-200/7	135	491	204	162	178.5	125	229	215	40	256.5				
U 5V-250/8	135	515	204	162	178.5	125	229	215	40	280.5				
U 5V-280/9	135	M 584 T 539	204	162	178.5	125	229	M 230 T 215	40	304.5				
U 5V-300/10	135	M 608 T 563	204	162	178.5	125	229	M 230 T 215	40	328.5				
U 5V-350/11	135	626	204	162	178.5	125	229	230	40	352.5				
U 7V-180/4	135	419	204	162	178.5	125	229	215	40	184.5			1"1/4 G	1"1/4 G
U 7V-250/5	135	443	204	162	178.5	125	229	215	40	208.5				
U 7V-300/6	135	467	204	162	178.5	125	229	215	40	232.5				
U 7V-350/7	135	552	204	162	178.5	125	229	230	40	256.5				
U 7V-400/8	135	576	204	162	178.5	125	229	230	40	280.5				
U 7V-450/9	135	633	204	162	178.5	125	235	250	40	304.5				
U 7V-550/10	135	657	204	162	178.5	125	235	250	40	328.5				
U 9V-200/4	135	443	204	162	178.5	125	229	215	40	208.5	1"1/2 G	1"1/4 G		
U 9V-250/5	135	473	204	162	178.5	125	229	215	40	238.5				
U 9V-300/6	135	M 548 T 503	204	162	178.5	125	229	M 230 T 215	40	268.5				
U 9V-400/7	135	578	204	162	178.5	125	229	230	40	298.5				
U 9V-450/8	135	641	204	162	178.5	125	235	250	40	328.5				
U 9V-500/9	135	671	204	162	178.5	125	235	250	40	358.5				
U 9V-550/10	135	701	204	162	178.5	125	235	250	40	388.5				
U 18V-250/3 T	135	451	204	162	178.5	125	229	215	50	213.5			2" G	1"1/2 G
U 18V-400/4 T	135	534	204	162	178.5	125	229	230	50	251				
U 18V-450/5 T	135	605	204	162	178.5	125	235	250	50	288.5				
U 18V-550/6 T	135	642	204	162	178.5	125	235	250	50	326				