

serie

ULTRA/S



ULTRA 18S

электронасосы
МНОГОСТУПЕНЧАТЫЕ



ХАРАКТЕРИСТИКИ / CHARACTERISTICS / CARACTERISTICAS / CARATERISTIQUES



ПРИМЕНЕНИЕ – многоступенчатый горизонтальный центробежный насос из нержавеющей стали. Перекачивание чистой без примесей жидкости в частном, сельскохозяйственном и промышленном секторе; системы повышения давления; ирригация; питьевая и гликолевая вода; водоочистительные системы; пищевая промышленность; системы отопления и кондиционирования воздуха; моечные системы.

ПРЕИМУЩЕСТВА – моноблочная компактная конструкция; бесшумность; превосходные показатели продуктивности, позволяющие значительно снизить эксплуатационные расходы и затраты энергии; экономичность; превышающие стандартные габариты подшипники для долговечности в эксплуатации; промежуточная направляющая вала для обеспечения соосности вращения.

ОСОБЕННОСТИ КОНСТРУКЦИИ – пропускная способность: до 26 м³/h; суммарная высота напора: до 78 м; максимальное рабочее давление: 8 бар (9 бар с 7 рабочими колесами); температурная зона жидкости: от -15 до + 110 °C; температура окружающей среды: до 40 °C.

ДВИГАТЕЛЬ - двухполюсный асинхронный электродвигатель; однофазные модели – 230 V – 50 Hz; с тепловой защитой; До P2 = 1,85 kW трехфазные модели – 230/400 V – 50 Hz; изоляция класса F; степень защиты IP 44.

МАТЕРИАЛЫ – корпус, рабочие колеса, диффузоры, кольцо герметизирующего уплотнения - хромоникелевая сталь AISI 304; вал привода насоса - хромоникелевая сталь AISI 304; опора двигателя - алюминиевый сплав; герметизирующее уплотнение – графитокерамика до 6 ступеней, графит-кремний – начиная с 7 ступеней; промежуточная направляющая вала - керамика-вольфрам; прокладки в корпусе насоса EPDM.



USES - Stainless steel multistage horizontal pumps. Pumping of clean non-loaded fluids in the domestic, agricultural and industrial sectors; pressurizing systems; irrigation; drinking and glycol water; water treatment; food industry; heating and air conditioning; washing system.

ADVANTAGES - Closed coupled and compact; silent; excellent efficiency that allows a reduction of running cost ad powers; economical; over-dimensioned bearings for longer life of the machines; intermediate shaft guiding stage for concentricity of rotation.

CONSTRUCTION FEATURES - Capacity: up to 26 m³/h; total Head: up to 78 m.; maximum working pressure: 8 bar (9 bar with 7 impellers); maximum liquid temperature: from -15 up to + 110 °C; ambient temperature: max 40 °C.

MOTOR - 2 pole induction Motor; single phase 230V - 50Hz with thermal protector up to P2= 1,85 Kw; three phase 230-400V - 50 Hz; insulation class F; protection degree IP 44.

MATERIALS - Pump body, impellers, diffusers, mechanical seal disc holder: chromo-nickel steel AISI 304; pump shaft: AISI 303 chromo-nickel steel; motor bracket: aluminum alloy; mechanical seal: ceramic-graphite up to 6 stages - graphite-silicon carbide from 7 stages; intermediate shaft guiding stage bush: ceramic-tungsten carbide; pump body gasket: EPDM.



UTILIZACIONES - Bombas centrífugas multietapas horizontales con cuerpo bomba y parte hidraulica en acero cromo-níquel Aisi 304. Bombeo de líquidos químicamente y mecánicamente no agresivos en el sector doméstico, agrícola e industria; sistemas de presurización; riegos; agua potable o con glycol; tratamientos del agua; industria alimenticia; calefacción y refrigeración; sistemas de lavado.

VENTAJAS - Versión monobloc compacta con medidas reducidas; extrema silenciosidad de funcionamiento; excelente rendimiento con desminución de los costes de ejercicio y de las potencias; economica; cojinetes del motor sobredimensionados para una mayor duración; cojinete intermedio guía-eje que garantiza la coaxialidad de rotación.

CARACTERÍSTICAS CONSTRUCTIVAS -Caudal hasta los 26 m³/h; prevalencia hasta los 78 mt.; maxima presión de ejercicio 8 bar (9 bar con 7 rodetes); temperatura de ejercicio del líquido bombeado: de -15 a + 110°C; temperatuta del ambiente max 40°C.

MOTOR - Motor de 2 polos a inducción; monofasico 230v-50hz dotado de protección térmica hasta P2= 1,85 kW; trifasico 230/400v-50hz; aislamiento clase F; protección IP44.

MATERIALES - Cuerpo bomba, rodetes, rifusores, disco sello mecánico: acero cromo-níquel AISI304; eje: acero cromo-níquel AISI303; soporte motor: aluminio estampado; sello mecánico: cerámica-grafito hasta los 6 estadios - grafito-carburo de silicio de los 7 estadios; cojinete intermedio guía-eje: ceramica-carburo de tungsteno; guarniciones cuerpo bomba: EPDM.



UTILISATION - Pompes multicellulaires horizontales en acier inox. Pour le pompage d'eaux propres non chargées pour des applications domestiques, agricoles, industrielles; groupes de surpression; irrigation; eau potable ou solution de glycol; traitement des eaux; industrie alimentaire; chauffage et Climatisation; stations de lavage auto.

AVANTAGES - Version monobloc compact; silencieux; rendement excellent avec une diminution remarquable des coût de fionnement et des puissance; économique; roulements surdimensionnés et étage de guidage intermédiaire pour une durée de vie prolongée des machines; roulement intermédiaire étage de guidage qui garantie le coaxialité de rotation.

CARACTÉRISTIQUES D'EXÉCUTION - Débit jusqu'à 26 m³/h; hauteur jusqu'à 78 m.; pression max. de fonctionnement 8 bar (9 bar avec 7 roues); température du liquide pompé: de -15 à + 110 °C; température ambiante max 40 °C.

MOTEUR - Moteur 2 pôles à induction; monophasé 230 V – 50 Hz avec protection thermique jusqu'à P2= 1,85 kW; triphasé 230/400 V – 50 Hz; isolation en classe F; degré de protection IP 44.

MATERIAUX - Corps de pompe, roues, diffuseurs, disque porte-garniture: acier au chrome-nickel AISI 304; arbre: acier au chrome-nickel AISI 303; support moteur: alliage d'aluminium; garniture mécanique: céramique – graphite jusqu'à 6 étages, graphite - carbure de silicium à partir de 7 étages; douilles étage de guidage intermédiaire: céramique -carbure de tungstène; joint corps de pompe: EPDM.



ULTRA 5S



ULTRA 9S



ULTRA 7S



ULTRA 3S

■ ■ ■ U 5 S - 120 / 4 T

- Трехфазные - Three-phase
- Количество рабочих колес - no. of impellers
- Номинальная мощность HPx100 - Nominal Power HPx100
- Нержавеющая сталь с гидравлической стороны - Stainless-steel hydraulic
- Номинальная пропускная способность м³/h - Nominal flow-rate m³/h
- Модель - Type **ULTRA**

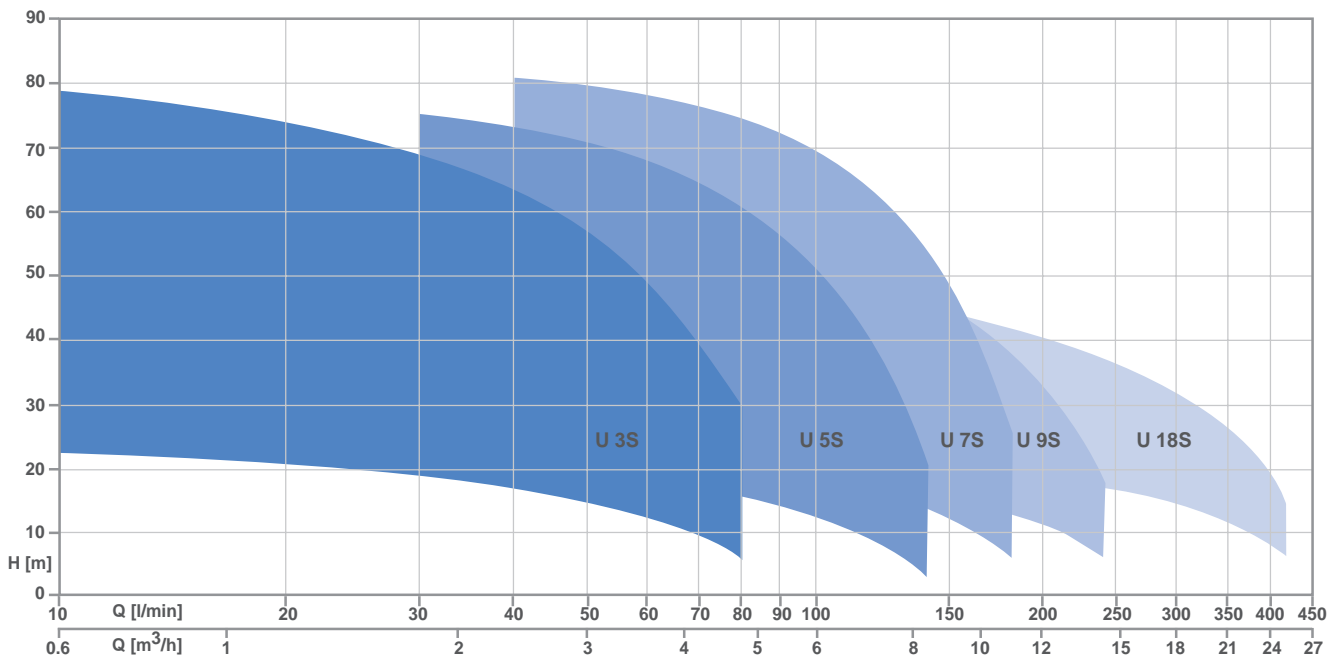

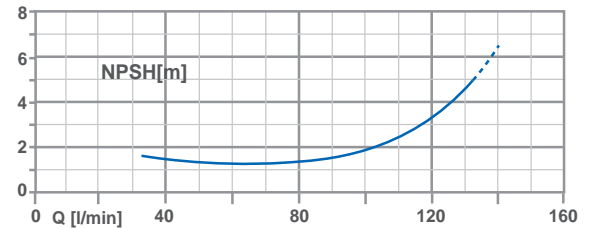
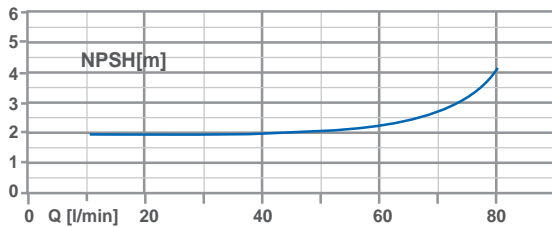
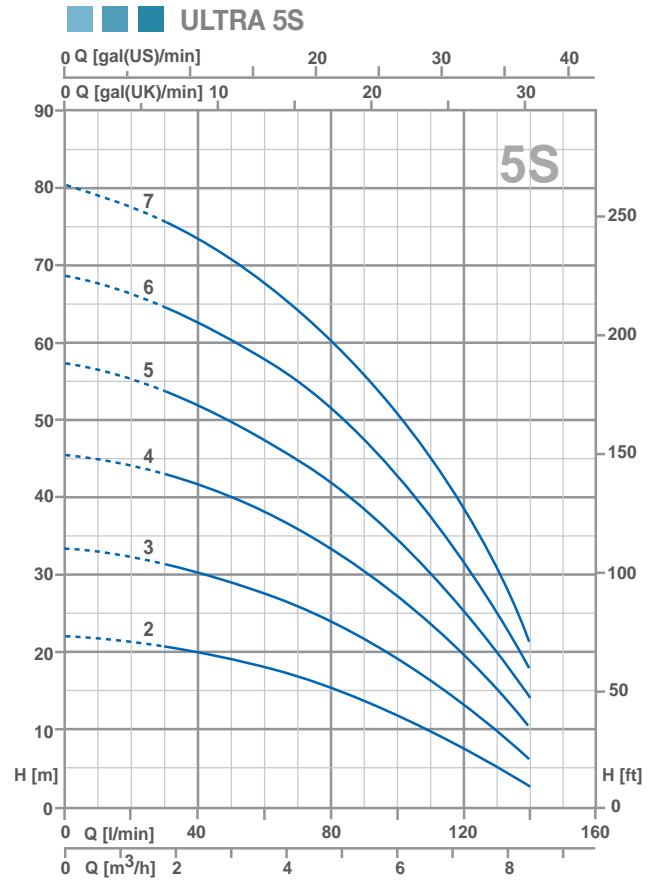
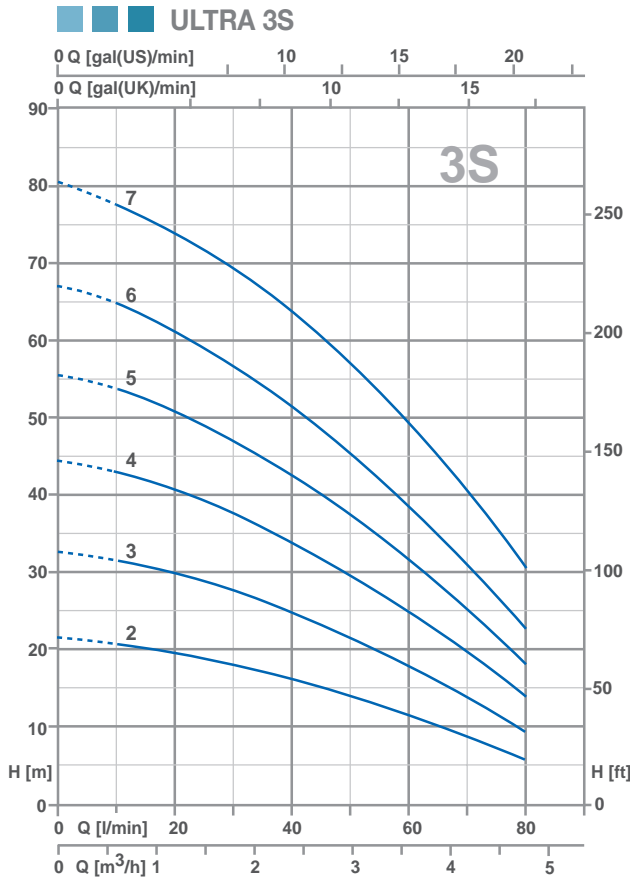

ТЕХНИЧЕСКИЕ ДАННЫЕ / Technical data / Datos técnicos / Données techniques

МОДЕЛЬ / TYPE / MODELO / MODÈLE		P2		P1 (kW)		AMPERE		Q (m³/h - l/min)							
1~	3~	(HP)	(kW)	1~	3~	1~	3~	0	0.6	1.2	1.8	2.4	3.6	4.8	
230 V - 50 Hz	230 / 400 V - 50 Hz							0	10	20	30	40	60	80	
U 3S-50/2	U 3S-50/2 T	0.5	0.37	0.42	0.41	1.8	0.9	21.7	20.9	19.3	17.8	15.9	11.4	5.8	
U 3S-70/3	U 3S-70/3 T	0.7	0.51	0.61	0.58	2.7	1.1	32.7	31.3	29.2	26.7	23.9	17.2	9	
U 3S-90/4	U 3S-90/4 T	0.9	0.66	0.82	0.8	3.6	1.7	44.3	42.8	40	36.4	33.2	24.5	13.9	
U 3S-100/5	U 3S-100/5 T	1	0.75	0.99	0.92	4.4	1.7	55.3	53.5	50.3	46.5	42.1	31.6	17.7	
U 3S-120/6	U 3S-120/6 T	1.2	0.9	1.11	1.11	5.1	2.5	66.6	64.4	60.8	56	50.7	38.1	22.4	
U 3S-150/7	U 3S-150/7 T	1.5	1.1	1.38	1.31	6.4	2.7	80.1	77.7	74.2	69.1	63.3	48.8	30	

МОДЕЛЬ / TYPE / MODELO / MODÈLE		P2		P1 (kW)		AMPERE		Q (m³/h - l/min)							
1~	3~	(HP)	(kW)	1~	3~	1~	3~	0	1.8	2.4	3.6	4.8	6	7.2	8.4
230 V - 50 Hz	230 / 400 V - 50 Hz							0	30	40	60	80	100	120	140
U 5S-70/2	U 5S-70/2 T	0.7	0.51	0.6	0.58	2.6	1.1	22.3	20.4	19.5	17.5	14.8	11.7	7.8	2.8
U 5S-80/3	U 5S-80/3 T	0.8	0.6	0.8	0.75	3.8	1.4	34	31.1	29.9	27	23.6	19.1	13.1	6
U 5S-120/4	U 5S-120/4 T	1.2	0.9	1.09	1.08	4.9	2.4	45.5	42.2	40.7	37.2	32.9	27.4	19.8	10.4
U 5S-150/5	U 5S-150/5 T	1.5	1.1	1.39	1.31	6.5	2.7	57.2	53.4	51.7	47.6	42.3	35.2	25.7	14
U 5S-180/6	U 5S-180/6 T	1.8	1.3	1.63	1.55	7.3	3	68.9	64.4	62.3	57.5	51.5	43.5	32.6	18.1
U 5S-200/7	U 5S-200/7 T	2	1.5	1.94	1.67	8.7	3.3	81	75.5	73	67.4	60.3	51	38.6	21

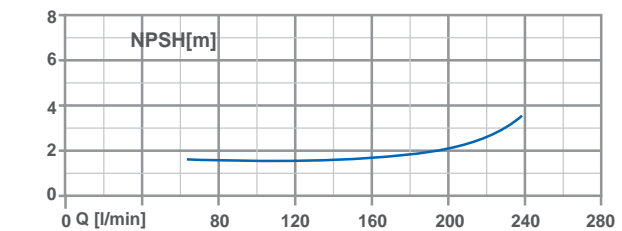
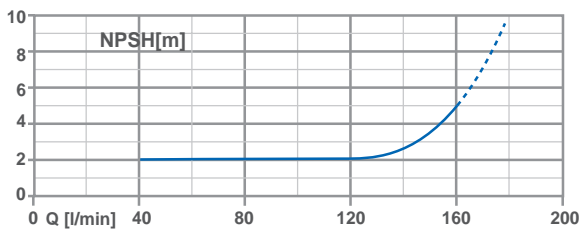
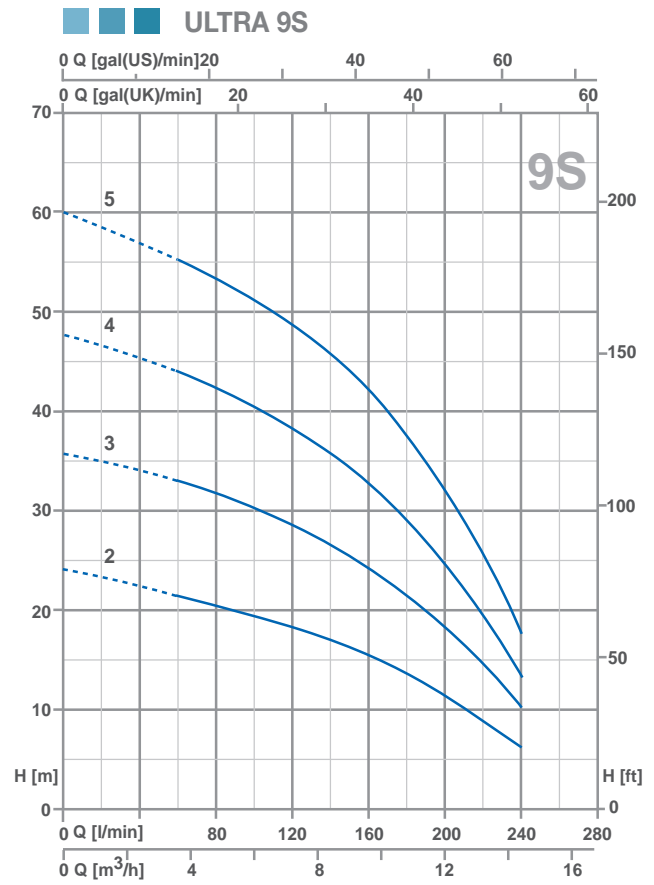
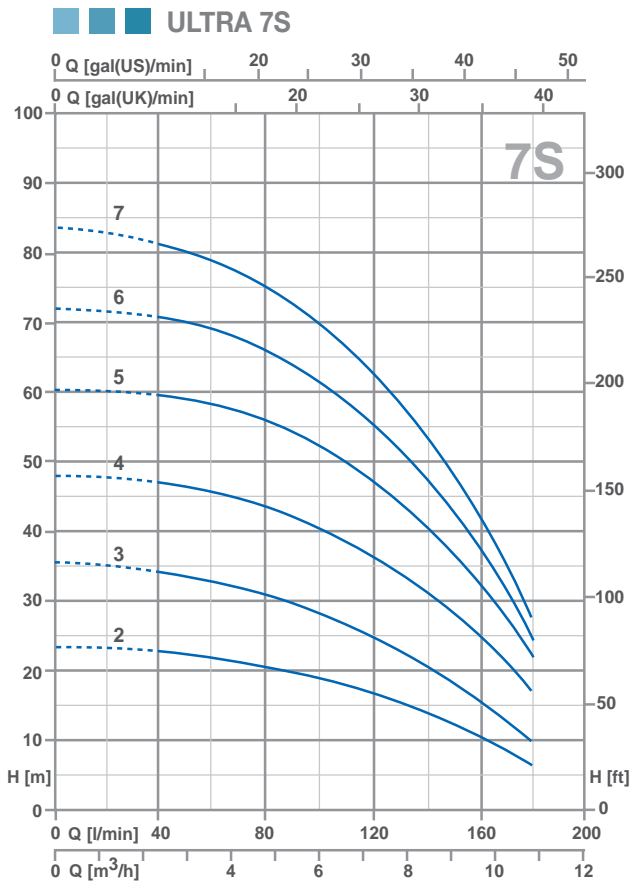

ТЕХНИЧЕСКИЕ ДАННЫЕ / Technical data / Datos técnicos / Données techniques

МОДЕЛЬ / TYPE / MODELO / MODÈLE		P2		P1 (kW)		AMPERE		Q (m³/h - l/min)								
1~	3~	(HP)	(kW)	1~	3~	1~	3~	H (m)								
230 V - 50 Hz	230 / 400 V - 50 Hz							1x230V 50Hz	3x400V 50Hz	0	2.4	3.6	4.8	6	7.2	8.4
U 7S-100/2	U 7S-100/2 T	1	0.75	0.91	0.84	4.1	1.6	23.6	22.6	21.8	20.5	18.8	16.7	13.9	10.6	6.7
U 7S-120/3	U 7S-120/3 T	1.2	0.9	1.23	1.22	5.6	2.5	35.6	33.9	32.8	31.2	28.1	24.7	20.8	15.7	10.0
U 7S-180/4	U 7S-180/4 T	1.8	1.3	1.69	1.62	7.7	3.1	48.0	46.3	45.7	43.6	40.4	36.4	31.4	25.0	17.2
U 7S-250/5	U 7S-250/5 T	2.5	1.85	2.19	2.05	10.2	4.1	60.3	59.0	58.2	55.7	52.2	47.4	41.3	33.5	22
-	U 7S-300/6 T	3	2.2	2.53	2.44	11.4	4.8	72.5	70.5	69.2	66	61.5	55.7	47.8	37.8	24.7
-	U 7S-350/7 T	3.5	2.57	-	2.84	-	5.1	83.5	80.7	78.8	74.7	69.4	62.6	53.9	42.7	27.5

МОДЕЛЬ / TYPE / MODELO / MODÈLE		P2		P1 (kW)		AMPERE		Q (m³/h - l/min)										
1~	3~	(HP)	(kW)	1~	3~	1~	3~	H (m)										
230 V - 50 Hz	230 / 400 V - 50 Hz							1x230V 50Hz	3x400V 50Hz	0	3.6	4.8	6	7.2	8.4	9.6	10.8	12
U 9S-100/2	U 9S-100/2 T	1	0.75	0.99	0.95	4.5	1.8	23.9	20.9	20	18.8	17.7	16.5	15	13.0	11	8.7	6
U 9S-150/3	U 9S-150/3 T	1.5	1.1	1.47	1.4	6.8	2.8	35.6	32.5	31.5	30	28.7	26.9	24.6	22	18.7	15	10.7
U 9S-200/4	U 9S-200/4 T	2	1.5	1.88	1.77	8.4	3.3	47.6	43.5	42.1	40.1	38.1	35.7	32.7	28.9	24.2	19	13.1
U 9S-250/5	U 9S-250/5 T	2.5	1.85	2.36	2.23	10.8	4.3	60	54.8	53	51	48.2	45.4	42	37.3	31.6	25	18

ULTRA/S

serie

электронасосы
МНОГОСТУПЕНЧАТЫЕ

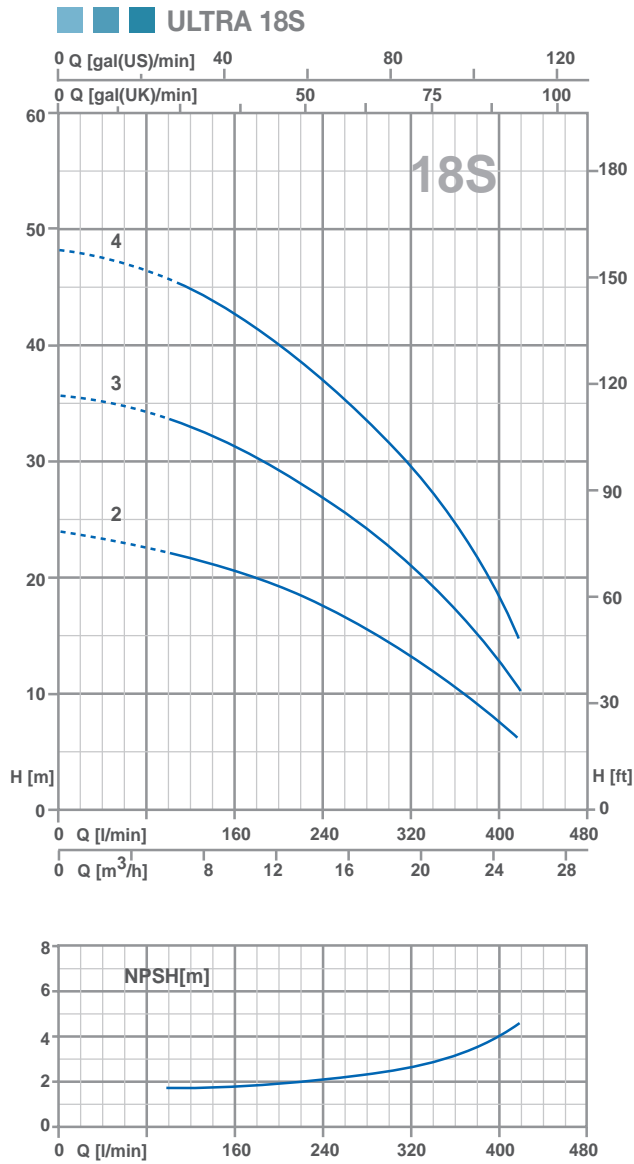

ТЕХНИЧЕСКИЕ ДАННЫЕ / Technical data / Datos técnicos / Données techniques

МОДЕЛЬ / TYPE MODELO/MODÈLE	P2		P1 (kW)	AMPERE	Q (m ³ /h - l/min)																	
					H (m)																	
					0	6	7.2	8.4	9.6	10.8	12	13.2	14.4	15.6	16.8	18	19.2	20.4	21.6	22.8	24	25.2
3~	(HP)	(kW)	3~	3~	0	100	120	140	160	180	200	220	240	260	280	300	320	340	360	380	400	420
230 / 400 V - 50 Hz				3~	3~	23.7	21.7	21.1	20.4	20	19.3	18.5	17.7	16.9	16	15.2	14.3	13.1	11.8	10.3	9.1	7.6
U 18S-180/2 T	1.8	1.3	1.59	3	23.7	21.7	21.1	20.4	20	19.3	18.5	17.7	16.9	16	15.2	14.3	13.1	11.8	10.3	9.1	7.6	6.4
U 18S-250/3 T	2.5	1.85	2.29	4.4	35.7	33.1	32.3	31.3	30.4	29.4	28.4	27.4	26.3	25.1	24	22.8	21.4	19.6	17.8	15.4	12.9	10.2
U 18S-400/4 T	4	3	3.11	5.7	47.9	45	44	42.8	41.7	40.5	39.1	37.8	36.6	35.2	33.9	32.2	30.2	28	25.1	22.1	18.1	14.9

ULTRA 3S - ULTRA 5S

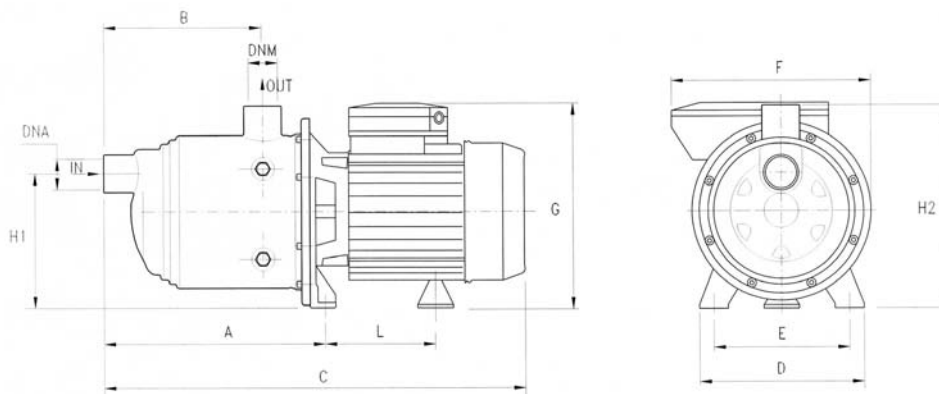

МОДЕЛЬ / TYPE MODELO / MODÈLE	РАЗМЕРЫ / DIMENSIONS / DIMENSIONES / DIMENSIONS (mm)										DNA	DNM
	A	B	C	D	E	F	G	L	H1	H2		
U 3S-50/2	166.8	103	333	164	140	178	195	93.7	128	192	1" G	1" G
U 3S-70/3	166.8	103	333	164	140	178	195	93.7	128	192		
U 3S-90/4	190.8	127	357	164	140	178	195	104.7	128	192		
U 3S-100/5	214.8	151	404	164	140	178	203	104.7	128	192		
U 3S-120/6	238.8	175	428	164	140	178	203	104.7	128	192		
U 3S-150/7	262.8	199	483	164	140	201	211	104.7	128	198		
U 5S-70/2	166.8	103	333	164	140	178	195	93.7	128	192		
U 5S-80/3	166.8	103	357	164	140	178	203	93.7	128	192		
U 5S-120/4	190.8	127	380	164	140	178	203	104.7	128	192		
U 5S-150/5	214.8	151	436	164	140	201	211	128.2	134	198		
U 5S-180/6	238.8	175	459	164	140	201	211	128.2	134	198		
U 5S-200/7	262.8	199	483	164	140	201	211	128.2	134	198		

РАЗМЕРЫ / Dimensions / Dimensiones / Dimensions
ULTRA 7S - ULTRA 9S - ULTRA 18S

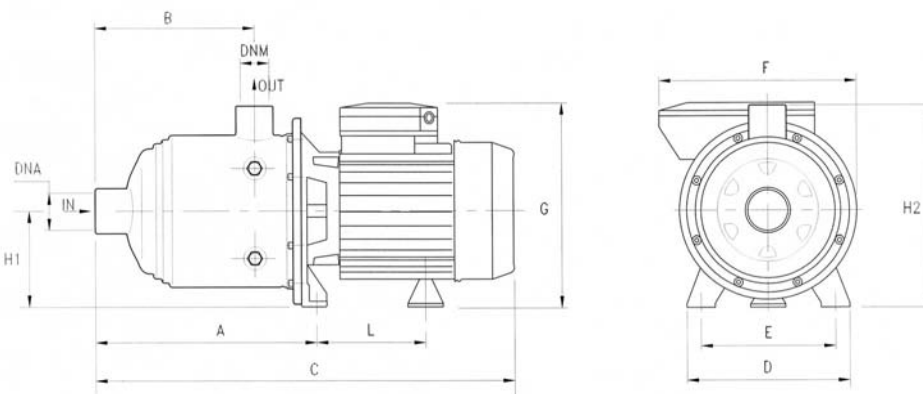

МОДЕЛЬ / TYPE MODELO / MODÈLE	РАЗМЕРЫ / DIMENSIONS / DIMENSIONES / DIMENSIONS (mm)										DNA	DNM
	A	B	C	D	E	F	G	L	H1	H2		
U 7S-100/2	166.8	103	356	164	140	178	203	93.7	92	192	1"1/4 G	1" G
U 7S-120/3	166.8	103	356	164	140	178	203	93.7	92	192		
U 7S-180/4	190.8	127	411	164	140	201	211	128.2	98	198		
U 7S-250/5	214.8	151	436	164	140	201	211	128.2	98	198		
U 7S-300/6	238.8	175	459	164	140	201	211	128.2	98	198		
U 7S-350/7	262.8	199	527	164	140	201	230	148.2	103	203		
U 9S-100/2	185.8	122	375	164	140	176	203	104.7	92	192	1"1/2 G	1"1/4 G
U 9S-150/3	185.8	122	375	164	140	201	211	128.2	98	198		
U 9S-200/4	216	152	436	164	140	201	211	128.2	98	198		
U 9S-250/5	246	182	464	164	140	201	211	128.2	98	198		
U 18S-180/2 T	201	137	432	164	140	201	211	128.2	98	198	2" G	1"1/2 G
U 18S-250/3 T	238.5	174.5	432	164	140	201	211	128.2	98	198		
U 18S-400/4 T	276	212	514	164	140	201	230	148.2	103	203		